

# Data Sheet

2019 v2.0

## SDM630MCTE-MID

### DIN Rail Multifunction Power Meter (MID Certified)

- MID B&D Certified by SGS UK
- Certified for Single & Three Phase
- Certified for Import / Export kWh
- Built in Pulse & Modbus Comms



## SDM630MCT-Modbus Multifunction Power Meter

The SDM630MCT is a new generation modern design power monitor that will measure and display electrical power quality parameters. It has been engineered to cover most applications (Single Phase and Three Phase networks / Built in Pulsed and RS485 Modbus / Import and Export kWh), replacing the need for several different models of this power meter.

As the demand for MID certified meters has increased, we have obtained annex B and D of the EC Directive 2004/22/EC. This power meter has been tested and certified for single or three phase networks and import and export active energy (kWh).

The SDM630MCT is produced to the highest quality and utilizes the latest microprocessor and technology. It has a blue backlit display and 16 different measuring parameters. This includes a negative power reading to indicate reversal of CT installation or connection. With built in pulsed outputs and RS485 Modbus RTU it is fully compatible for integration with BMS and remote monitoring systems.

### Parameters

- Phase to Neutral Voltage (V)
- Phase Current (A)
- Frequency (Hz)
- Power Factor (PF)
- Active Power (kW)
- Reactive Power (kVAR)
- Apparent Power (kVA)
- Import Active Energy (kWh)
- Export Active Energy (kWh)
- Total Active Energy (kWh)
- Import Reactive Energy (kVAh)
- Export Reactive Energy (kVAh)
- Total Reactive Energy (kVAh)

# Specifications

## Measured Parameters

The unit can monitor and display the following parameters of a Single Phase Two Wire (1P2W) or Three Phase Four Wire (3P4W) system.

## Voltage and Current

- Phase to Neutral Voltages 100-289V AC (not for 3P3W supplies).
- Phase to Phase Voltages 173-500V AC (3 Phase supplies only).

## Power factor and Frequency and Max. Demand

- Frequency in Hz
- Instantaneous power:
- Power 0-3600 MW
- Reactive Power 0-3600 MVA
- Volt-Amps 0-3600 MVA
- Power factor

## Energy Measurements

Imported/Exported active energy	0 to 9999999.9 kWh
Imported/Exported reactive energy	0 to 9999999.9 kVAh
Total active energy	0 to 9999999.9 kWh
Total reactive energy	0 to 9999999.9 kVAh

## Measured Inputs

Voltage inputs through 4-way fixed connector with 2.5mm<sup>2</sup> stranded wire capacity. Single Phase Two Wire(1P2W or Three Phase Four Wire (3P4W) unbalanced. Line frequency measured from L1 Voltage or L3 Voltage. Three Current inputs (six physical terminals) with 2.5mm<sup>2</sup> stranded wire capacity for connection of external CTs. Nominal rated input Current 5A or 1A AC Rms.

Nominal Voltage Input	100-289V AC (Ph+N) or 173-500V AC (Ph+Ph)
Max Continuous Voltage	120% of Nominal
Nominal Input Current	0.25-5A(6)A AC RMS
Max Continuous Current	120% of Nominal
Nominal Input Current Burden	0.5VA
Frequency	50Hz ±10%

## Accuracy

Voltage	0.5% of range maximum
Current	0.5% of nominal
Frequency	0.2% of mid-frequency
Power Factor	1% of unity (0.01)
Active Power (W)	±1% of range maximum
Reactive Power (VAR)	±1% of range maximum
Apparent Power (VA)	±1% of range maximum
Active Energy (Wh)	Class 1 IEC 62053-21
ReactiveEnergy (VARh)	±1% of range maximum
Response time to step input	1s, typical, to >99% of final reading, at 50 Hz.

## Auxiliary Supply

Two-way fixed connector with 2.5mm<sup>2</sup> stranded wire capacity. 85-275V AC 50Hz ±10% or 120-380V DC ±20%. Consumption <2W 10VA.

Operating range

85-275V AC  $\pm 10\%$  / 120-380V DC  $\pm 20\%$

## Interfaces for External Monitoring

Three interfaces are provided:

- RS485 communication channel that can be programmed for Modbus RTU protocol
- Relay output indicating real-time measured energy (configurable)
- Pulse output 3200IMP/kWh (not configurable)

The Modbus configuration (baud rate etc.) and the pulse relay output assignments (kW/kVAh, import/export etc.) are configured through the set-up screens.

## Pulse Output

Opto-coupler with potential free SPST-NO Contact (Contact rating - Voltage: 5-27V DC, Current: I<sub>min</sub> 2mA and I<sub>max</sub> 27mA DC). The pulse output can be set to generate pulses to represent kWh or kVAh.

Rate can be set to generate 1 pulse per:

0.01 = 10 Wh/VArh  
0.1 = 100 Wh/VArh  
1 = 1 kWh/kVAh  
10 = 10 kWh/kVAh  
100 = 100 kWh/kVAh

Pulse width 200/100/60 ms.

## RS485 Output for Modbus RTU

For Modbus RTU, the following RS485 communication parameters can be configured from the set-up menu:

Baud Rate: 2400, 4800, 9600, 19200, 38400

Parity: None (default) / Odd / Even

Stop Bits: 1 or 2

RS485 Network Address: 3 Digit Number - 001 to 247

Modbus<sup>®</sup> Word order Hi/Lo byte order is set automatically to normal or reverse. It cannot be configured from the set-up menu.

## Reference Conditions of Influence Quantities

Influence Quantities are variables that affect measurement errors to a minor degree. Accuracy is verified under nominal value (within the specified tolerance) of these conditions.

Ambient temperature	23°C $\pm 1^\circ\text{C}$
Input waveform	50 or 60Hz $\pm 2\%$
Input waveform	Sinusoidal (distortion factor < 0.005)
Auxiliary supply voltage	Nominal $\pm 1\%$
Auxiliary supply frequency	Nominal $\pm 1\%$
Auxiliary supply waveform (if AC)	Sinusoidal (distortion factor < 0.05)
Magnetic field of external origin	Terrestrial flux

## Environment

Operating temperature	-25°C to +55°C*
Storage temperature	-40°C to +70°C*
Relative humidity	0 to 95%, non-condensing
Altitude	Up to 3000m
Warm up time	1 minute
Vibration	10Hz to 50Hz, IEC 60068-2-6, 2g
Shock	30g in 3 planes

\*Maximum operating and storage temperatures are in the context of typical daily and seasonal variation.

## Mechanics

DIN rail dimensions	72 x 94.5 mm (WxH) per DIN 43880
Mounting	DIN rail (DIN 43880)
Sealing	IP51 indoor
Material	Self-extinguishing UL 94 V-0

## Dimensions

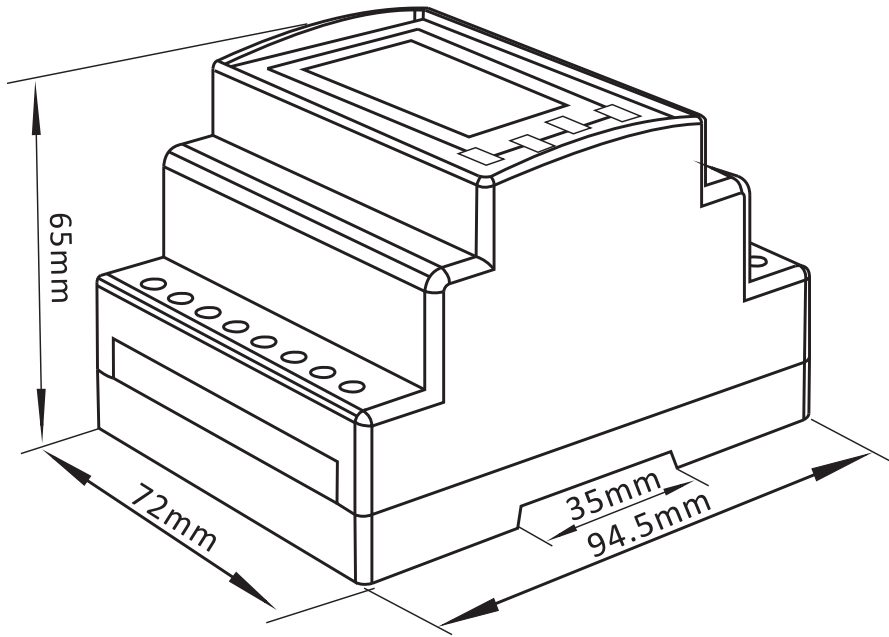

## Installation

