

MULTICAL® 403

kamstrup

## The front runner in energy metering

- Lower your costs with reduced stock levels
- Save time and minimize installation costs
- Decrease your total lifetime investment



# Geared for the future

MULTICAL® 403 is an investment for the future. The meter is equipped to meet the demands and challenges of today and tomorrow. The meter is available with separated software download to either meter or communication module to enable future upgrades as new possibilities and challenges occur without interfering with legal registers, meter readings or network management.



MULTICAL® 403 is based on innovative ultrasonic technology, a deep understanding of the challenges faced by utilities and decades of experience with designing and manufacturing high-quality heat and cooling meters. Simple-to-use functionality, unrivalled accuracy and reliability ensure that each meter or integrated solution is perfectly equipped to optimize efficiency and support future development.

## Reduce your stock with the most flexible meter

Now, you only need one meter in stock! MULTICAL® 403 fits many applications, and everything from the energy unit to the inlet/outlet position of the flow sensor and much more can be individually configured directly on site via the front keys. This allows you to keep a low stock, be more cost-effective and save resources previously spent on planning.

The meter selection ranges from  $q_p$  0.6 to  $q_p$  15 m<sup>3</sup>/h. MULTICAL® 403 can therefore be used in applications ranging from houses and apartments to shopping centres and office buildings.

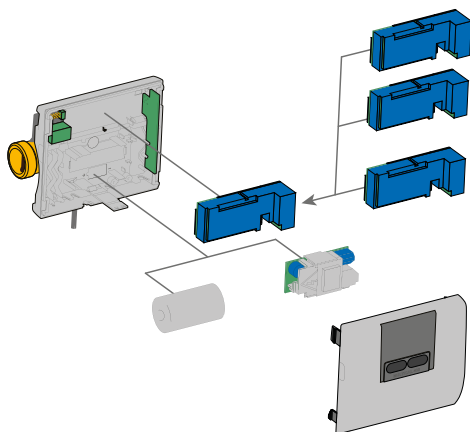

## Save time with quick and simple installation

Installation has never been easier or faster than with MULTICAL® 403. One screwdriver is all you need for mounting the meter. The compact design means that the meter can easily fit all types of installations while still maintaining an optimal display angle even in narrow environments.

The rugged design and high quality of MULTICAL® 403 means that it is virtually maintenance-free while reconfiguration or service of the meter is easily completed due to the simple setup. Therefore, the time and cost spent on installations and maintenance are lower than ever before.

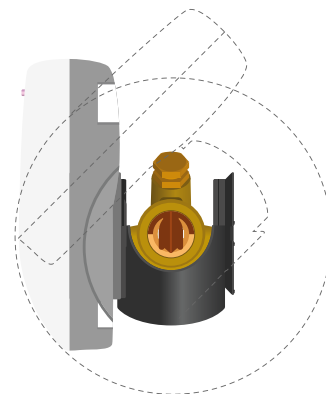

## Optimize your operations with instant access to data

Forget that you ever needed direct access to read a meter's data logger. MULTICAL® 403 offers full support for remote reading to speed up billing and gives you instant access to the information needed to analyse and optimise the distribution network.

The data logger in MULTICAL® 403 is programmable to save yearly, monthly, daily and hourly values – at intervals of as low as one minute. Just decide which data you need at what intervals. This lets you effectively analyse and diagnose your application for faster identification of load profiles, errors and inconsistencies.

MULTICAL® 403 can be equipped with a wide range of advanced communication modules, e.g. M-Bus or Wireless M-Bus. You can also read out the data logger in MULTICAL® 403 at desired intervals via the communication modules. The improved M-Bus allows fast and frequent data read-outs without reducing the battery lifetime. This gives you instant access to data and decreases the overall lifetime cost of the meter.

## Keep down costs and increase return on investment

MULTICAL® 403 has been optimised compared to earlier generations. The total dynamic range has been increased to 1600:1 from saturation flow to start flow, and the meter has been approved up to 250:1 from permanent flow to minimum flow.

This ensures that any possible consumption is measured with the same renowned precision - which means accurate billing.

Even with an increased dynamic range, MULTICAL® 403 requires less pumping capacity than its predecessors, as the pressure loss is below 0.15 bar. This applies to all flow sizes of up to 15 m<sup>3</sup>/h. This reduces the consumption of the circulation pumps and limits the energy loss in the installation to a bare minimum. All of this lowers the total lifetime cost of MULTICAL® 403 and ensures a larger return on investment.

The meter can be powered with several mains or battery options depending on your needs. As battery supply, you can either choose a smaller battery without transport restrictions or go for a bigger battery with up to 16 years lifetime. No matter what solution you choose, battery and mains, the own consumption of MULTICAL® 403 is extremely low. This lowers your operational costs, keeps down the total lifetime cost of each meter and helps minimise CO<sub>2</sub> emissions.

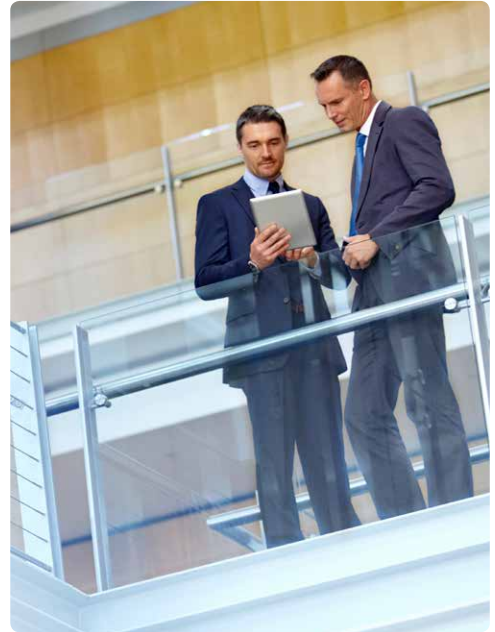

## Think forward

---

### **Kamstrup A/S**

Industrivej 28, Stilling  
DK-8660 Skanderborg  
T: +45 89 93 10 00  
F: +45 89 93 10 01  
info@kamstrup.com  
kamstrup.com